

SUBSCRIBER LINE INTERFACE CIRCUIT

PRELIMINARY DATA

- MONOCHIP SILICON SLIC SUITABLE FOR PUBLIC/PRIVATE APPLICATIONS
- IMPLEMENTS ALL KEY FEATURES OF THE BORSCHT FUNCTION
- SOFT BATTERY REVERSAL WITH PROGRAMMABLE TRANSITION TIME (3 to 100ms)
- METERING PULSE INJECTION AND FILTERING WITH MINIMAL COMPONENTS COUNT (NO TRIMMING REQUIRED).
- PROTECTION RESISTOR MISMATCH COMPENSATION
- ON HOOK TRANSMISSION
- LOOP START/GROUND START FEATURE
- IND TEMP. RANGE:
 - L3037 0°C TO 70°C
 - L3037T -40°C to +85°C
- LOW POWER DISSIPATION IN ALL OPERATING MODES
- INTEGRATED ZERO CROSSING RELAY DRIVER
- INTEGRATED (NOISE-LESS) RING TRIP DETECTION
- VERY LOW NO. of STD TOLERANCE EXTERNAL COMPONENTS
- SELECT PART FOR U.S. APPLICATIONS (63dB TYP. LONG. BALANCE)

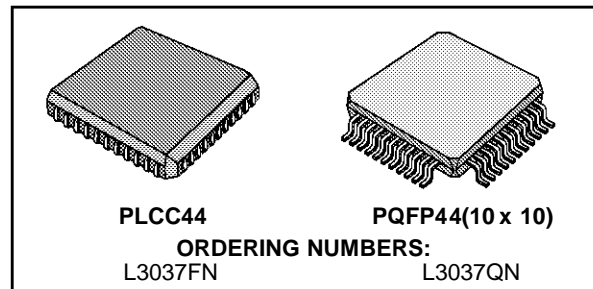

- SURFACE MOUNT PACKAGE (PLCC44 or PQFP44)
- INTEGRATED THERMAL PROTECTION
- PIN TO PIN COMPATIBLE WITH L3035/36

DESCRIPTION

The L3037 subscriber line interface circuit is a bipolar device in 70V technology developed for central office / loop carrier and private applications.

The L3037 is pin to pin and function compatible with L3035/36. One particular pin (reserved in L3035/36) is now used for reverse polarity transition time programming. The line polarity transition is not affecting the AC signal transmission that can continue also during the line voltage transition. L3037 is available in two different package options: PLCC44 and PQFP44 (10 x 10mm).

BLOCK DIAGRAM

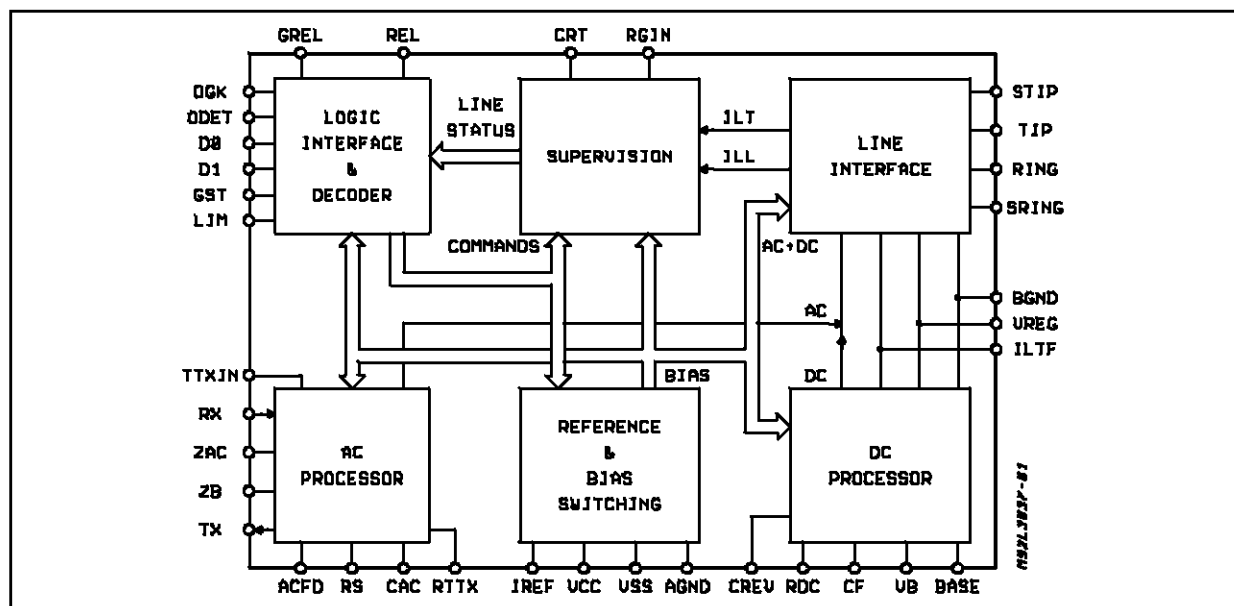

L3037 PIN FUNCTIONALITY (PLCC44)

No.	Name	Function
1	V _{CC}	Supply input (+5V)
2	I _{LT} F	Analog output (current source)
3	RDC	Analog input (current input)
4	CF	Analog input (voltage input)
5	BASE	Analog output (voltage source)
6	BGND	Ground input (0V)
7	VREG	Supply input (VREG)
8	STIP	Analog input (voltage input)
9	TIP	Analog output (voltage output)
10 to 14	VB	Supply input (-V _{BAT})
15	RING	Analog output (voltage output)
16	SRING	Analog input (voltage input)
17	CRT	Analog input/output (voltage input / current output)
18	ODET	Digital output (voltage output with internal pull up)
19	RGIN	Analog input (current input)
20	OGK	Digital output (voltage output with internal pull up)
21	GST	Digital input (voltage input, internal pull down)
22	D1	Digital input (voltage input)
23	D0	Digital input (voltage input)
24	LIM	Digital input (voltage input 3 levels: 0, +5, open)
25	V _{SS}	Supply input (-5V)
26	REL	Digital output (voltage output open drain)
27	CREV	Analog input/output (voltage input/current output)
28	GREL	Ground input (0V)
29	CAC	Analog input (current input)
30	RS	Analog input/output (current output/voltage input)
31	ZB	Analog input (voltage input)
32 to 36	VB	Supply input (-V _{BAT})
37	Tx	Analog output (voltage output)
38	Rx	Analog input (voltage input)
39	Z _{AC}	Analog output (voltage output)
40	TTXIN	Analog input (voltage input)
41	RTTX	Analog output (voltage output)
42	ACFD	Analog input (voltage input)
43	AGND	Ground input (0V)
44	I _{REF}	Analog input/output (voltage output/current input)

L3037 FUNCTIONAL DIAGRAM

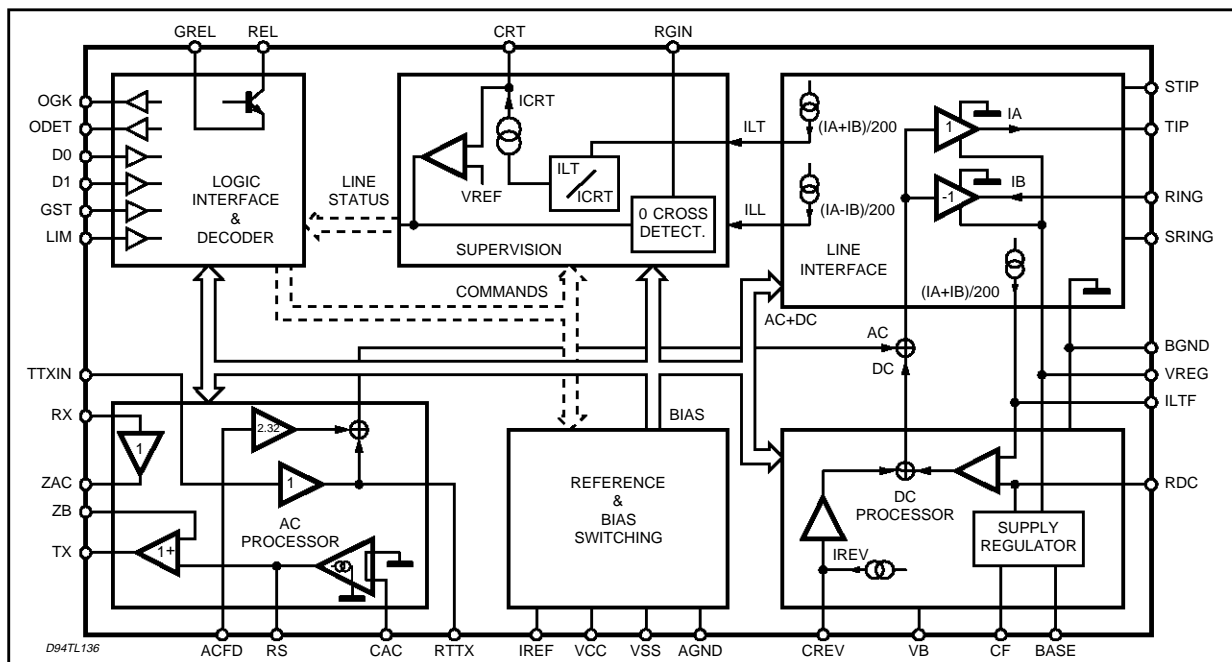

PIN CONNECTION (Top view)

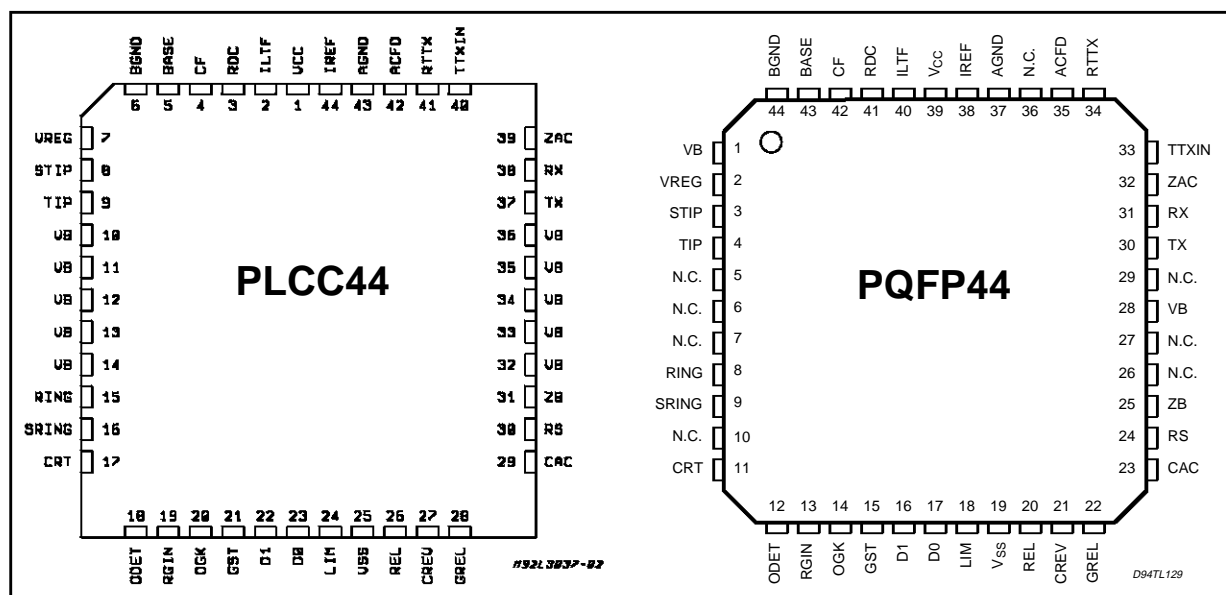

ABSOLUTE MAXIMUM RATINGS

Symbol	Parameter	Value	Unit
V_{bat}	Battery Voltage	-64 to $V_{SS}+0.5$	V
V_{CC}	Positive Supply Voltage (0 to 1ms) (continuous)	-0.4 to +7 -0.4 to +5.5	V
V_{SS}	Negative Supply Voltage (0 to 1ms) (continuous)	-7 to +0.4 -5.5 to +0.4	V
$V_{agnd} - V_{bgnd}$	Agnd Respect Bgnd (continuous)	-2 to +2	V
V_{REL}	Ring Relay Supply Voltage	14	V
V_{dig}	Digital I/O D0, D1, GST, LIM, ODET, OGK	-0.4 to +5.5	V
I_{dig}	Digital I/O D0, D1, GST, LIM, ODET, OGK	-3 to +3	mA
T_j	Maximum Junction Temperature	+150	°C
T_{stg}	Storage Temperature	-55 to +150	°C
Hu	Humidity	5 to 95	%

Note: In case of power on, power failure or hot insertion with V_{DD} , V_{SS} present and V_{bat} floating the Absolute Maximum Ratings can be exceeded with $V_{bat} > V_{SS} + 0.5V$. In this case the power consumption of the device increases and the logic output state including relay driver are not controlled. This effect can be prevented ensuring that V_{bat} is always present before V_{DD} and V_{SS} or connecting one shottky diode (e.g. BAT49X or equivalent) between V_{bat} and V_{SS} . One diode can be shared between all the SLICs of the same line card.

OPERATING RANGE

Symbol	Parameter	Value	Unit
T_{op}	Operating Temperature Range	0 to +70 -40 to +85	°C
$V_{agnd} - V_{bgnd}$	Difference between Agnd and Bgnd	-2 to +2	V
V_{CC}	Positive Supply voltage	+4.5 to +5.5	V
V_{SS}	Negative Supply Voltage	-5.5 to -4.5	V
V_{bat}	Battery Voltage	-62 to -24	V
V_{REL}	Ring Relay Supply Voltage	4 to 13	V

THERMAL DATA

Symbol	Parameter	PLCC44	PQFP44	Unit
$R_{th\ j-amb}$	Thermal Resistance Junction-ambient	Max. 45	75	°C/W

PIN DESCRIPTION

Unless otherwise specified all the diagrams in this datasheet refers to the PLCC44 Pin Connection.

PQFP44 No.	PLCC44 No.	Pin	Description
39	1	V _{CC}	Positive Power Supply (+5V)
40	2	I _{LTF}	Transversal Line Current Image ($(I_A + I_B) / 200$)
41	3	RDC	DC feedback input (the RDC resistor is connected from this node to I _{LTF})
42	4	CF	Battery voltage ripple rejection (C _{SVR} capacitor is connected from this node to BGND).
43	5	BASE	Driver for external transistor base
44	6	BGND	Battery ground
2	7	VREG	Regulated Voltage. Provides negative power supply for the power amplifier. (connected to emitter of the external transistor.)
3	8	STIP	Input of A power amplifier (when no compensation of ext. ptc resistor mismatch is requested it must be shorted to the TIP lead).
4	9	TIP	A line termination output (I _A is the current sourced from this pin).
1, 28	10 to 14 32 to 36	VB	Battery Supply PLCC44: All pins are internally connected together. PQFP44: It is mandatory to short pin 1 and pin 28 as closed as possible to the device.
8	15	RING	B line termination output (I _B is the current sunk into this pin).
9	16	SRING	Input of B power amplifier (when no compensation of ext. ptc resistor mismatch is requested it must be shorted to the RING lead).
11	17	CRT	Ring trip and ground key capacitor
12	18	ODET	ON/OFF hook and RING TRIP output (when disable is internally pulled up)
13	19	RGIN	Ring input signal. (when open is internally pulled to GND)
14	20	OGK	Ground key output (when disable is internally pulled up)
15	21	GST	A open command (when open is internally pulled down)
16	22	D1	Bit 1
17	23	D0	Bit 0
18	24	LIM	Current Limitation Program. (when open is internally forced to 44mA current limitation)
19	25	V _{SS}	Negative Power Supply (-5V)
20	26	REL	Ring relay driver output
21	27	CREV	Reverse polarity transition time control. One proper capacitor connected between this pin and AGND is setting the reverse polarity transition time. If reverse polarity feature is not used must be shorted to AGND.
22	28	GREL	Ground reference for ring relay driver
23	29	C _{AC}	AC feedback input (ACDC split capacitor is connected from this node to I _{LTF})
24	30	R _S	Protection resistors image (the image resistor is connected from this node to ACFD)
25	31	Z _B	Balance network for 2 to 4 wire conversion (the balance impedance Z _B is connectet from this node to AGND. The Z _A impedance is connected from this node to Z _{AC})
30	37	Tx	4 wire output port (Tx output)
31	38	Rx	4 wire receiving port. (Rx input)
32	39	Z _{AC}	Rx buffer output (the AC impedance is connected from this node to ACFD)
33	40	TTXIN	Metering input port/V _{drop} programming. If not used should be connected to AGND.
34	41	R _{TTX}	Metering cancellation network. If not used should be left open.
35	42	ACFD	AC impedance synthesis
37	43	AGND	DC and AC signal ground
38	44	I _{REF}	Voltage Reference Output
2,5 to 7, 10,26, 27, 29,36	–	N.C.	Not connected

DESCRIPTION (continued)

One special selection with high longitudinal balance performances allows to meet the United States BELLCORE requirements for central office/loop carrier and private applications.

The SLIC integrates loop start, ground start, ground key on/off-hook, automatic ring-trip as well as zero crossing ring relay driver.

Two to four wire conversion is implemented by the SLIC for application with first generation COMBO. In case of application with second generation (programmable) COMBO this function can be implemented outside saving external components.

The L3037 offers programmable current limitation (3 ranges), on hook transmission and low power in all operating modes, power management is controlled by a simple external low cost transistor.

Metering pulses are injected on the line via a summing node through TTXIN pin.

Metering pulse filtering is performed by means of a simple RC network with standard tolerance components. In case TTX function is not used this pin must be connected to AGND. It is also possible to use this pin to modify the DC voltage drop between TIP/RING terminals and battery voltage for applications where it is important to optimize the battery voltage supply versus the signal swing.

Effect of protection resistors mismatch are compensated by a feedback loop on the final stage allowing good long balance performances also with large tolerance protection resistors (ex: PTC).

This function allow the L3037 to be fully conform to BELLCORE power cross and surge test and meet also the Longitudinal Balance Specification without using matched PTC resistors.

An integrated thermal protection circuit forces the L3037 in POWER DOWN (PD) mode when the junction temperature exceeds 150°C Typ.

The L3037 is specified over -40°C to +85°C ambient temperature range.

The L3037 package is a surface mount PLCC44 or PQFP44.

FUNCTIONAL DESCRIPTION

L3037 is designed in 70V bipolar technology and performs the telephone line interface functions required in both C.O. and PABX environments. The full range of signal transmission, battery feed, loop supervision are performed.

Signal transmission performance is compatible with European and North American Standards and with CCITT recommendations.

Ringing, overvoltage and power cross protection are performed by means of external networks.

The signal transmission function includes both 2 to 4 wire and 4 to 2 wire conversion. The 2W termination impedance is set by means of an external impedance which may be complex. The 2 to 4

wire conversion is provided by means of an external network.

Such a network can be avoided in case of applications with COMBOII, in this case the 2 to 4 wire conversion is implemented inside the COMBOII by means of the programmable Hybal filter.

An additional input allows a metering pulse signal to be added on the line.

The DC feed resistance is programmable with one external resistor. Three different values of current limitation (25, 44, 55mA) can be selected by software through the parallel digital interface.

One external transistor reduces the power dissipation inside the L3037 in the presence of a short loop (limiting current region).

An additional supervisory function sets the TIP lead into high impedance state in order to allow application in ground start configurations.

The different L3037 operating modes are controlled by a 4bit logic interface, two additional detector outputs provide ground key detection and either hook state or ring trip detection.

SLIC OPERATING MODES

Through the L3037 digital interface it is possible to select 5 different SLIC operating modes:

- 1) Active Mode (ACT)
- 2) Standby Mode (SBY)
- 3) Tip Open Mode (TO)
- 4) Power Down Mode (PD)
- 5) Ringing Mode (RNG)

In both ACT and SBY modes it is possible to select the reverse polarity (see control interface).

Transition from direct to reverse polarity is soft and the transition time is defined by the external capacitor CREV.

ACTIVE MODE (ACT)

This operating mode is set by the card controller when the Off-Hook condition has been recognized.

When this operating mode is selected the two output buffers (TIP/RING) can sink or source up to 100mA each. In case of Ground key or line terminals to GND the output current is limited to 15mA for the Tip wire and 30mA for the Ring wire.

As far as the DC characteristic is concerned three different feeding conditions are present:

a) Current limiting region: the DC impedance of the SLIC is very high (20Kohm) and therefore the system works like a current source. Using the L3037 digital interface it is possible to select the value of the limiting current:

25mA, 44mA, or 55mA.

When the device is in limiting current region the negative supply for the output buffer is fixed by

the ext. transistor to a proper value higher than the real negative battery in order to reduce the power dissipated by the L3037 itself.

b) Resistive feed region: the characteristic is equal to a battery voltage (Vbat) in series with a resistor (typ 400ohm or 800ohm) whose value is set by one ext. resistor (see ext. components list).

c) Constant voltage region: the characteristic is equal to the battery voltage - 12V in series with the ext. protection resistors (typ 80ohm).

This voltage drop between battery and line terminals for $I_l=0$ allows on-hook transmission.

Fig. 1 shows the DC characteristic in active mode. Fig. 2 shows the line current versus loop resistance

Figure 1: DC Characteristic in active mode

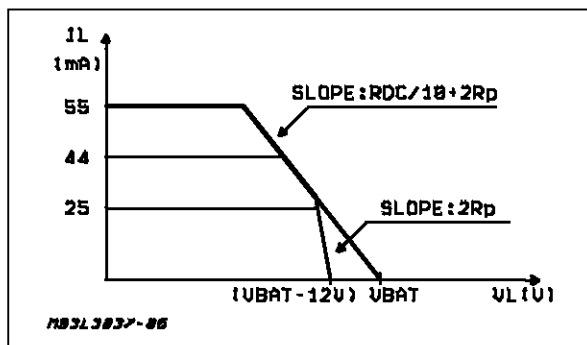
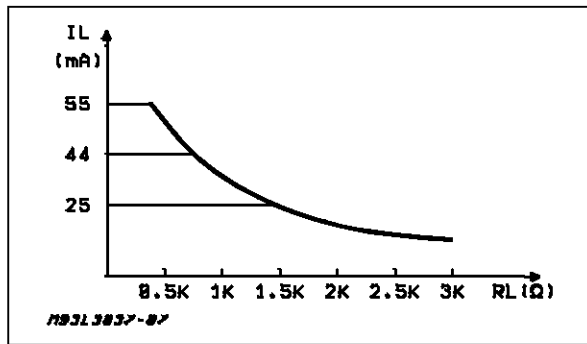

Figure 2: Current vs. Loop Resistance. $R_{feed} = 2 \times 200\text{ohm}$, Lim. currents: 25, 43, 55mA



In active mode the AC impedance at the line terminals is synthesized by the external components ZAC and Rp according to the following formula:

$$Z_s = Z_{AC}/50 + 2 \cdot R_p$$

Depending on the characteristic of the ZAC network Zs can be either a pure resistance or a complex impedance. This allows L3037 to meet different standard as far as return loss is concerned. The capacitor CCOMP guarantees stability to the system.

The two to four wire conversion is achieved by means of a circuit that can be represented as a Wheatstone bridge, the branches of which are:

- 1) The line impedance (Zline)
- 2) The SLIC impedance at line terminals (Zs)
- 3) The balancing network ZA+RA connected between pin ZAC and ZB of L3037.
- 4) The network ZB between pin ZB and GND that shall copy the line impedance.

When L3037 is used with a second generation combo (eg TS5070FN) which is able to perform the two to four wire conversion, the two impedances ZA and ZB can be removed and the ZB pin connected to GND. The -6dB TX gain of the L3037 allows the echo signal to remain always within the COMBOII Hybrid balance filter dynamic range.

The injection of high frequency metering pulses is carried out through the SLIC. An unbalanced 12 or 16KHz sinusoidal signal with shaping is, when necessary, applied at the TTXIN input of the SLIC.

A fixed transfer gain is provided for the metering signal. To avoid saturation in the 4-wire side a cancellation is provided in the 4-wire transmission path.

Cancellation is obtained via an external RC network without the need for trimmed components.

When the TTX function is not used TTXIN input should be connected to GND. Since this pin is directly connected to a summing node inside the SLIC any signal applied to the TTXIN is transferred to the line with a fixed transfer gain.

In special applications, this pin can be used to modify the voltage drop (constant voltage region of DC characteristic) simply by applying a proper DC level on the TTXIN pin, allowing optimization of the battery voltage versus the maximum needed AC signal swing.

In active mode, with a -48V battery voltage, the L3037 dissipate 150mW for its own operation (including the power dissipation from +5/-5 supply), the dissipation related to the current supplied to the line should be added in order to get the total dissipation.

STAND-BY MODE (SBY)

In this mode the bias current of the L3037 is reduced and only some part of the circuit are completely active. The transversal current supplied to the line is limited at 14mA. Common mode current rejection is performed and the total current capability of the output stages (TIP and RING) is limited to 30mA. The open circuit voltage is $|V_{bat}|-7V$.

Both Off/Hook and Ground key detectors are active. Signal transmission is not operating.

In stand-by mode, with a -48V battery voltage, the L3037 dissipates 90mW typ. (including the power dissipation from a +5/-5V supply).

Stand-by mode is usually selected when the telephone is in on-hook condition. It allows a proper off-hook detection, even in the presence of high common mode currents, or with telephone sets sinking a few milliamperes of line current in on-hook condition.

CONTROL INTERFACE

INPUTS				OPERATING MODE	OUTPUTS	
D0	D1	GST	LIM		ODET	OGK
0	0	0	X	POWER DOWN	DISABLE	DISABLE
1	1	0	X	STANDBY D. P.	OFF/HK	GDKEY
1	1	1	X	STANDBY R. P.	OFF/HK	GDKEY
1	0	0	X (*)	ACTIVE D. P.	OFF/HK	GDKEY
1	0	1	X (*)	ACTIVE R. P.	OFF/HK	GDKEY
0	1	0	X	RING	RING-TRIP	DISABLE
0	0	1	X	A. OPEN	OFF/HK	GDKEY
0	1	1	X	RESERVED	-	-

(*) LIM = 0 → $I_{lim} = 25\text{mA}$; LIM = H. I. (open) → $I_{lim} = 44\text{mA}$; LIM = 1 → $I_{lim} = 55\text{mA}$.

TIP OPEN MODE (TO)

This mode is selected when the SLIC is adopted in a system using the Ground start feature. In this mode the TIP termination is set in High Impedance (100Kohm) while the RING termination is active and fixed at $V_{bat} + 4.5\text{V}$. In the case of connection of RING termination to GND the sinked current is limited to 30mA. When RING is connected to GND both off-hook and ground-key detectors become active.

Power dissipation in this mode with a -48V battery voltage is 100mW (including the power dissipation from +5/-5V supply).

POWER DOWN MODE (PD)

In this mode, both TIP and RING terminations are open and no current is fed into the line.

The power dissipation is very low.

This mode is usually selected in emergency condition or when the connected line is disabled.

This is also the mode into which the SLIC is automatically forced, in the case of thermal overload $T_j > 150^\circ\text{C}$ typ.

RINGING MODE (RNG)

When this mode is selected the ringing signal is injected on the line via the ext relay activated by the L3037 relay driver.

When the ringing signal phase is provided at the RGIN pin, the relay command is also synchronized with the ringing signal zero crossing.

The TIP and RING termination of the L3037 senses the line current which is then integrated on the CRT capacitor.

TIP pin voltage is fixed at -2.5V , RING pin voltage is fixed at $V_{BAT} + 4.5\text{V}$, TIP, RING buffer current capability is limited to 100mA.

When off-hook occurs during ringing burst the voltage on CRT increase above a proper threshold and ring trip is detected.

Once ring trip is detected the ringing signal is automatically disconnected at the first zero crossing. When the ringing signal phase is not provided at the RGIN pin the ringing signal is disconnected immediately after ring trip detection.

EXTERNAL COMPONENTS LIST

To set the SLIC into operation the following parameters have to be defined:

- The DC feeding resistance "Rfeed" defined as the resistance of the traditional feeding system (most common Rfeed values are: 400, 800, 1000 ohm).
- The AC SLIC impedance at line terminals "Zs" to which the return loss measurements is referred. It can be real (typ. 600ohm) or complex.
- The equivalent AC impedance of the line "Zl" used for evaluation of the trans-hybrid loss performance (2/4wire conversion). It is usually a complex impedance.
- The value of the two protection resistors Rp in series with the line termination.
- The line impedance at the TTX freq. Zltx.
- The reverse polarity transition time defined as " $\Delta V_{TR}/\Delta T$ ".

Once, the above parameters are defined, it is possible to calculate all the external components using the following table.

The typical values has been obtained supposing:

- Rfeed = 400Ω
- Zs = 600Ω
- Zl = 600Ω
- Rp = 40Ω
- Zltx = 216Ω + 120nF @ 12KHz
- Re[Zltx] = 216Ω
- Im[Zltx] = -110Ω @12KHz
- $\Delta V_{TR}/\Delta T = 4250[\text{V/s}]$

EXTERNAL COMPONENTS

Name	Function	Formula	Typ. Value
CVB	Battery Filter		330nF 20% 63VI
CVDD	Positive Supply Filter		100nF 20%
CVSS	Negative Supply Filter		100nF 20%
RREF	Internal Current Reference		23.7K 1%
CSVR	Battery Ripple Rejection	$CSVR = 1/(6.28 * f_p * 150K)$ @ $f_p = 1.6Hz$	680nF 20% 60VI
CRT	Ring Trip & Ground-key Capacitor	$CRT = (25/f_{RING}) \cdot 390nF$	390nF 20% 6VI
RDC	DC Feeding Resistance	$RDC = 10 * (R_{feed} - 2R_p)$	3.2K 1%
CAC	AC/DC Splitter	$CAC = 1 / (6.28 * f_{sp} * RDC)$ @ $f_{sp} = 10Hz$	4.7μF 20% 15VI
RS	Protection Resistor Image	$RS = 50 * 2R_p$	4K 1%
ZAC	2 Wire AC Impedance	$ZAC = 50 * (Z_s - 2R_p)$	26K 1%
ZA (1)	SLIC Impedance Balancing Network	$ZA = 50 * (Z_s - 2R_p)$	26K 1%
RA (1)	SLIC Impedance Balancing Network	$RA = 50 * 2R_p$	4K 1%
ZB (1)	Line Impedance Balancing Network	$ZB = 50 * Z_l$	30K 1%
CCOMP	AC Feedback Compensation	$CCOMP = 1 / [2\pi f_o (100 R_p)]$ @ $f_o = 250KHz$	220pF 20%
CH (1)	Trans-hybrid Loss Frequency Compensation	$CH = CCOMP$	220pF 20%
RF	Feeding Resistance for Ring Inj.	$\geq 200\Omega$ (7)	200Ω 2W
RT	Feeding Resistance for Ring Inj.	$\geq 200\Omega$ (7)	200Ω 2W
RRG	Ring Input Resistor	$RRG = (V_{RING}/25\mu A) \cos[-2 \cdot f_{RING} \cdot T \cdot 180]$ (4)	4MΩ 5%
CRG	Ring Input Capacitor	$CRG = 25\mu A / (V_{RING} \cdot \sin[2 \cdot f_{RING} \cdot T \cdot 180] \cdot 2\pi f_{RING})$ (4)	3.9nF 20% 100V
PTC (2)	Positive Temp. Coeff. Resistor	$< 15\Omega$	10Ω
RST (2)	Tip Buffer Sensing Resistor	10 to 50KΩ	33K 1W 5% (6)
RSR (2)	Ring Buffer Sensing Resistor	10 to 50KΩ	33K 1W 5% (6)
QEXT	External Transistor (3)		(*)
Rp	Protection Resistor	30 to 80Ω (8)	40Ω
RTTX	Teletax Cancellation Resistor	$RTTX = 21.5 \cdot [Re(Z_{ltx}) + 2R_p]$ (5)	6.34K 1%
CTTX	Teletax Cancellation Capacitor	$CTTX = 1 / (21.5 \cdot [-Im(Z_{ltx}) - f_{ttx} \cdot 6.28])$ (5)	5.6nF 20%
D1	Relay Kickback Clamp Diode		1N4148
CREV	Polarity Reversal Transition Time Programming	$CREV = \frac{K}{\Delta V_{TR}/\Delta T}$; $K = 2 \cdot 10^{-4}$	47nF

Notes:

- (1) These components can be removed and ZB pin shorted to GND when 2/4wire conversion is implemented with 2nd generation COMBO (EG. TS5070FN)
 - (2) In case there is no necessity to recover the unbalance introduced by PTC tolerance pins TIP and STIP can be shorted together as pins RING and SRING. In this case also the R_p Resistor should be splitted in two parts keeping at least 20Ω between TIP/RING terminals and protection connection. In this case PTC or fuse resistor (if used) can be placed in series to R_p.
 - (3) Transistor characteristic: P_{DISS} = 1W (typ. depending on application); h_{FE} ≥ 25; I_C ≥ 100mA; V_{CEO} ≥ 60V; f_T ≥ 15MHz.
 - (4) V_{RING}: Max Ring Generator Voltage, f_{RING}: Ring Frequency, T: relay response time.
Typical value obtained for V_{RING} = 100V_{rms}, f_{RING} = 25Hz; T = 2.5ms.
 - (5) Defining RTTX + CTTX = ZTTX, RTTX and CTTX can also be calculated from the following formula: Z_{F_{TTX}} = 21.5 [Z_{ltx} + 2R_p].
 - (6) RST and RSR wattage should be calculated according to the power cross test specification. (When PTC become open circuit the entire power cross voltage will appear across RSR and RST).
 - (7) In order to optimize the component count it is also possible to use only one resistor in series to the ringing generator. In this case RT = 0Ω; R_F ≥ 400Ω (R_F typ. value = 400Ω).
 - (8) Suggested R_p type are 2W wire wound resistors or thick film resistors on ceramic substrate.
Fuse function should be included if PTC are not used.
- (*) ex: BD140; MJE172; MJE350....(ST32 or SOT82 package available also for surface mount).
For low power application (reduced battery voltage) BCP53 (SOT223 surface mount package) can be used.

L3037

In case of U.S. application based on L3035 the external components can be calculated suppo-
sing:

- Rfeed = 400Ω

- Zs = 900Ω + 2.12μF
 - Zl = 1650Ω// (100Ω + 5nF) Loaded Line
 - Zl = 800Ω// (100Ω + 50nF) Not Loaded Line
 - Rp = 62Ω

EXTERNAL COMPONENTS (for US. Application)

Name	Function	Formula	Typ. Value
CVB	Battery Filter		330nF 20% 63VI
CVDD	Positive Supply Filter		100nF 20%
CVSS	Negative Supply Filter		100nF 20%
RREF	Internal Current Reference		23.7K 1%
CSVR	Battery Ripple Rejection	CSVR = 1/(6.28 * fp * 150K) @ fp = 1.6Hz	680nF 20% 60VI
CRT	Ring Trip & Ground-key Capacitor	CRT = (25/fRING) · 390nF	390nF 20% 6VI
RDC	DC Feeding Resistance	RDC = 10 * (Rfeed - 2Rp)	2.76K 1%
CAC	AC/DC Splitter	CAC = 1 / (6.28 * fsp * RDC) @ fsp = 10Hz	4.7μF 20% 15VI
RS	Protection Resistor Image	RS = 50 * 2RP	6.2K 1%
ZAC	2 Wire AC Impedance	ZAC = 50 * (Zs-2Rp) (7)	39K + (180K//55nF)
ZA (1)	SLIC Impedance Balancing Network	ZA = 50 * (Zs-2Rp) (7)	39K + (180K//55nF)
RA (1)	SLIC Impedance Balancing Network	RA = 50 * 2Rp	6.2K 1%
ZB (1)	Line Impedance Balancing Network	ZB = 50 * Zl	82.5K + (5K + 100pF) (3) 40K + (5K + 1nF) (4)
CCOMP	AC Feedback Compensation	CCOMP = 1 / [2Iifo (100 Rp)] @ fo = 250KHz	100pF 20%
CH (1)	Trans-hybrid Loss Freq. Comp.	CH = CCOMP	100pF 20%
RF	Feeding Resistance for Ring Inj.	≥ 200Ω (9)	200Ω 2W
RT	Feeding Resistance for Ring Inj.	≥ 200Ω (9)	200Ω 2W
RRG	Ring Input Resistor	RRG = (VRING/25μA)cos[-2·fRING · T · 180] (6)	4MΩ 5%
CRG	Ring Input Capacitor	CRG = 25μA/(VRING · sin[2 · fRING · T · 180] · 2IIfRING (6)	3.9nF 20% 100V
PTC (2)	Positive Temp. Coeff. Resistor	< 15Ω	10Ω
RST (2)	Tip Buffer Sensing Resistor	10 to 50KΩ	33K 1W 5% (8)
RSR (2)	Ring Buffer Sensing Resistor	10 to 50KΩ	33K 1W 5% (8)
QEXT	External Transistor (5)		(*)
Rp	Protection Resistor	30 to 80Ω (10)	62Ω
D1	Relay Kickback Clamp Diode		1N4148

Notes:

- (1) These components can be removed and ZB pin shorted to GND when 2/4wire conversion is implemented with 2nd generation COMBO (EG. TS5070FN)
 - (2) In case there is no necessity to recover the unbalance introduced by PTC tolerance pins TIP and STIP can be shorted together as pins RING and SRING. In this case also the Rp Resistor should be splitted in two parts keeping at least 20Ω between TIP/RING terminals and protection connection. In this case PTC or fuse resistor (if used) can be placed in series to Rp.
 - (3) Loaded Line.
 - (4) Not Loaded Line.
 - (5) Transistor characteristic: PDISS = 1W (typ. depending on application); hFE ≥ 25; IC ≥ 100mA; VCEO ≥ 60V; fT ≥ 15MHz.
 - (6) VRING: Max Ring Generator Voltage, fRING: Ring Frequency, T: relay response time. Typical value obtained for VRING = 100Vrms, fRING = 25Hz; T = 2.5ms.
 - (7) For details see AN496.
 - (8) RST and RSR wattage should be calculated according to the power cross test specification. (When PTC become open circuit the entire power cross voltage will appear across RSR and RST).
 - (9) In order to optimize the component count it is also possible to use only one resistor in series to the ringing generator. In this case RT = 0Ω; RF ≥ 400Ω (RF typ. value = 400Ω).
 - (10) Suggested Rp type are 2W wire wound resistors or thick film resistors on ceramic substrate. Fuse function should be included if PTC are not used.
- (*) ex: BD140; MJE172; MJE350... (SOT32 or SOT82 package available also for surface mount).
 For low power application (reduced battery voltage) BCP53 (SOT223 surface mount package) can be used.

Figure 5: Typical Application Circuit for U.S. Application.

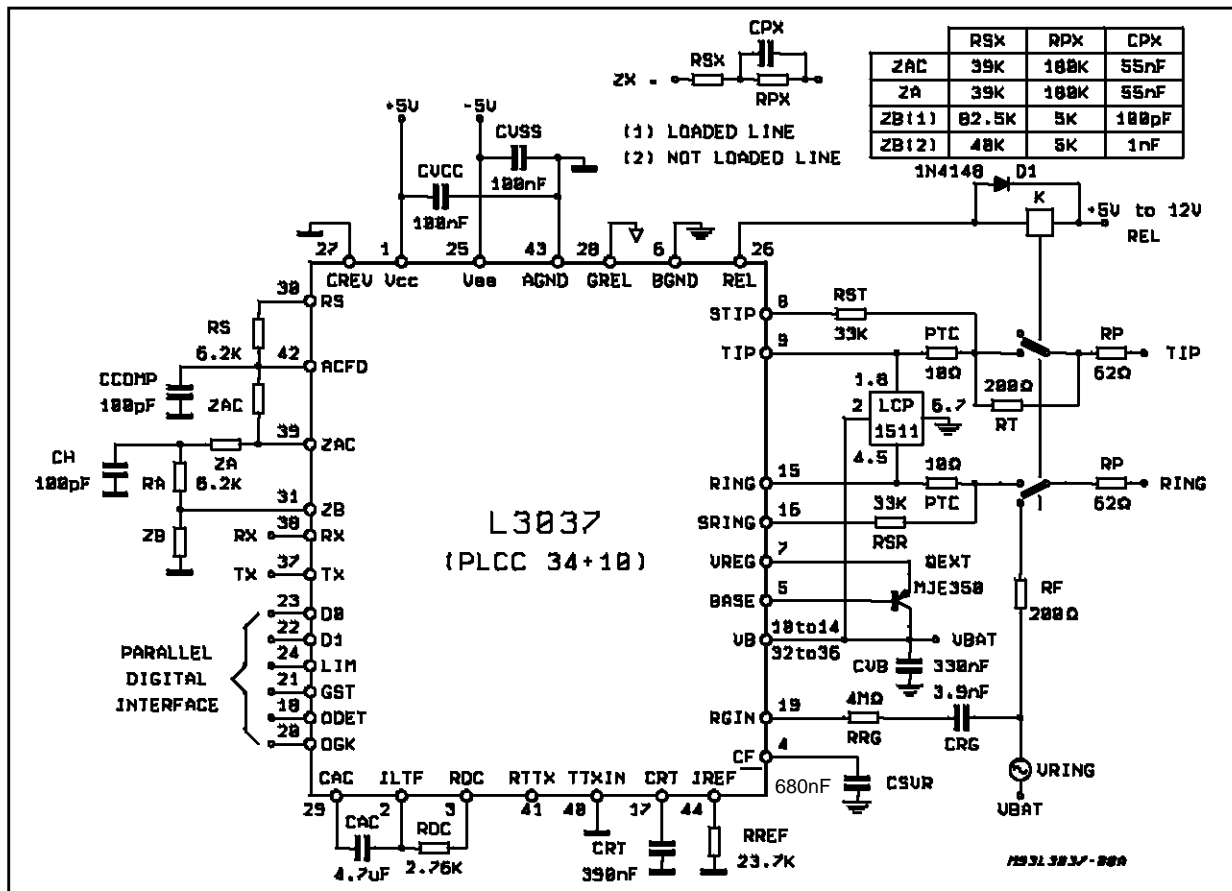

ELECTRICAL CHARACTERISTICS TEST CONDITION, unless otherwise specified: $V_{CC} = 5V$; $V_{SS} = -5V$; $V_{BAT} = -48V$; $AGND = BGND$; Direct Polarity; $T_A = 25^\circ C$.

Note: Testing of all parameter is performed at $25^\circ C$. Characterization as well as the design rules used allow correlation of tested performances at other temperatures. All parameters listed here are met in the range $0^\circ C$ to $+70^\circ C$. Additional selection (on request ordering part #: L3037T) can be performed so that the functionality between $-40^\circ C$ and $85^\circ C$ is verified.

Symbol	Parameter	Test Condition	Min.	Typ.	Max.	Unit
--------	-----------	----------------	------	------	------	------

INTERFACE REQUIREMENTS 2 WIRE PORT

V_{ab}	Overload Level Voice Signal	$R_p + PTC = 50\Omega$ 300Hz to 3.4KHz (*)	4.1			Vpk
Z_{II}	Long Input Impedance	at SLIC terminals per wire			10	Ω
I_{II}	Long Current Capab. ac	standby per wire (on HOOK)	17			mApk
I_{II}	Longitudinal Current Capability	active per wire (on HOOK)	17			mApk
I_{II}	Longitudinal Current Capability	active per wire off HOOK ($I_T =$ Transversal current)	$75-I_T$			mApk

4 WIRE TRANS PORT

V_{tx}	Overload Level		1.8			Vpk
V_{toff}	Output Offset Voltage		-350		+350	mV
Z_{tx}	Output Impedance				10	Ω

(*) At TIP/RING line connection with $Z_{LINE} (AC) = 600\Omega$. For any DC Loop current from 0mA to I_{LIM}

ELECTRICAL CHARACTERISTICS (continued)

Symbol	Parameter	Test Condition	Min.	Typ.	Max.	Unit
4 WIRE RECEIVE PORT						
Z _{RX}	Input Impedance		100			KΩ
V _{RX}	Overload Level		3.2			V _{pk}
METERING INPUT PORT						
Z _{MIN}	Input Impedance		100			KΩ
LOGIC CONTROL PORT INPUT D0, D1, GST						
V _{ih}	Input High Voltage		2			V
V _{il}	Input Low Voltage				0.8	V
I _{ih}	Input High Current		-10		90	μA
I _{il}	Input Low Current		-10		10	μA
C _{in}	Input Capacitance				10	pF
INPUT LIM						
V _{ih}	Input High Voltage		2.4			V
V _{il}	Input Low Voltage				0.4	V
I _{ih}	Input high Current		-10		30	μA
I _{il}	Input Low Current		-30		10	μA
C _{in}	Input Capacitance				10	pF
OUTPUT DET						
V _{ol}	Output Low Voltage	I _o = 2mA			0.4	V
V _{oh}	Output High Voltage	I _o = 30μA I _o ≤ 10μA	2.4 3.8			V V
C _{ld}	Load Capacitance				150	pF
RINGING INPUT PORT						
	Overload Level		-0.5		0.5	V
	Input Impedance		50		90	KΩ
	Offset Voltage Allowed		-15		15	mV

TRANSMISSION PERFORMANCE

A _{rl}	Return Loss (2-wire)	300Hz to 3.4KHz	22			dB
Th _l	Transhibrid Loss	300Hz to 3.4KHz $20\log_{10} \left \frac{V_{RX}}{V_{TX}} \right $	30			dB
Longitudinal balance (CCITT Rec.0.121)						
L-T	Longit to Transversal	300Hz to 3.4KHz Z _S = 600Ω R _P = 40Ω, 1% tolerance	52			dB
L-4	Long Sign Rejection		58			dB
T-L	Transvers to Longit		49			dB
4-L	Long Sign Generation		49			dB
Selected L3037 Longitudinal balance (IEEE Std 455-1976)						
L – T	Longitudinal to Transversal	300Hz to 3.4KHz Z _S = 900Ω + 2.12μF R _P = 62Ω, 1% match	58	63		dB
L – 4	Longitudinal Signal Rejection			70		dB

ELECTRICAL CHARACTERISTICS (continued)

Symbol	Parameter	Test Condition	Min.	Typ.	Max.	Unit
INSERTION LOSS						
G_t	Transmit V Gain	0dBm, 1KHz	-6.22		-5.82	dB
G_r	Receive V Gain		-0.2		0.2	dB
INSERTION LOSS vs. FREQUENCY (rel 1KHz / 0dBm)						
G_t	Transmit V Gain	0.3 to 3.4KHz	-0.1		0.1	dB
G_r	Receive V Gain		-0.1		0.1	dB
METERING INJECTION						
G_{TTX}	Transfer Gain	$V_{TTXIN} = 0.66V_{rms}$ $Z_L = 200\Omega$; $2 \cdot R_P = 80\Omega$; $V_{moff} = 0$	3.18		3.51	
THD	Harmonic Distortion				5	%
GAIN LINEARITY (rel 1KHz, -4dBm)						
G_t	Transmit V Gain	-55dBm to 7dBm (1)	-0.1		0.1	dB
G_r	Receive V Gain		-0.1		0.1	dB
GROUP DELAY (2-4, 4-2) 0dBm						
T_{gABS}	Absolute	3KHz		5		μs
T_{gDIS}	4 to 2-wire	0.5 to 3,4KHz		5		μs
TOT HARMONIC DISTORTION						
Thd4	2 to 4-wire	7dBm, 0.3 to 3.4KHz			-46	dB
Thd2	4 to 2-wire				-46	dB
IDLE CHANNEL NOISE						
V_{abp}	2-wire port	psophometric		-78	-72	dBmP
V_{txp}	4-wire transmit	psophometric		-82	-76	dBmP
V_{abc}	2-wire port	c message		12	18	dBrnC
V_{txc}	4-wire transmit	c message		8	14	dBrnC

RINGING FUNCTION

0 cross	Zero Crossing Threshold Level	$f_{RING} = 16$ to $66Hz$ $R_{GIN} = 3V_{rms}$	-70		70	mV
I_{RT}	Ring Trip Threshold			7.5		mA DC
T_{RTD}	Ring Trip Detection Time	$R_L = 1.8k$, $f_{RING} = 25Hz$			150	ms

BATTERY FEED CHARACTERISTIC

POWER DOWN STATE						
I_{LGND}	Loop Current	TIP or RING to BGND			0.5	mA
I_{LBAT}	Loop Current	TIP or RING to V_{bat}			0.5	mA
I_L	Loop Current	$R_L = 0$			1	mA
STAND BY STATE						
I_l	lloop Accuracy	constant region	13		16	mA
V_{LOS}	Line Voltage	@ $I_L = 0$	40		42	V
ACTIVE STATE						
V_{LO}	Line Voltage	@ $I_L = 0$	34.5		37.5	V
R_{feed}	Feeding Resistance Accuracy		-10		+10	%
I_{lim}	Loop Current Limit Accuracy	$I_{lim} = 25mA, 44mA, 55mA$	-8	I_{lim}	+8	%
GROUND START STATE						
Z_{TIP}	Tip Lead Impedance		100			K Ω
I_{GS}	Ring Lead Current	RING to GND		30		mA

(1) For level lower than -40dB guaranteed by correlation.

ELECTRICAL CHARACTERISTICS (continued)

Symbol	Parameter	Test Condition	Min.	Typ.	Max.	Unit
--------	-----------	----------------	------	------	------	------

DETECTORS

OFF HOOK DETECTOR						
I_{det}	Off-hook Current Threshold	stand by state	9		12	mA
I_{det}	Off-hook Current Threshold	active state	9		12	mA
Hys	Off-hook / On-hook Hysteresys	Both stand by and active state	1		1.6	mA
T_d	Dialling Distortion	active state	-1		1	ms
GROUND KEY DETECTOR						
I_{LL}	Ground Key Current Threshold $I_{LL} = (I_B - I_A) / 2$	TIP to RING to GND or RING to GND		4		mA

POWER DISSIPATION ON L3037 at $V_{BAT} = 48V$

P_d	Power Down	any line lenght			38	mW
P_d	Stand-by	2-wire open $R_L = 0$ to 2K		95	136 250	mW mW
P_d	Active, $R_{feed} = 800\Omega$ $I_{LIM} = 25mA$ $I_{LIM} = 44mA$ $I_{LIM} = 55mA$	2-wire open $R_L = 0$ to 2K $R_L = 0$ to 2K $R_L = 0$ to 2K		155	224 710 1730 2660	mW mW mW mW
P_d	Active, $R_{feed} = 400\Omega$ $I_{LIM} = 25mA$ $I_{LIM} = 44mA$ $I_{LIM} = 55mA$	2-wire open $R_L = 0$ to 2K $R_L = 0$ to 2K $R_L = 0$ to 2K		155	224 510 870 1280	mW mW mW mW
P_d	Active	Ground Key		1500		mW

POWER DISSIPATION ON QEXT AT $V_{bat} = 48V$

P_{dq}	Active, $R_{feed} = 800\Omega$ $I_{LIM} = 25mA$ $I_{LIM} = 44mA$ $I_{LIM} = 55mA$	$R_L = 0$ to 2K $R_L = 0$ to 2K $R_L = 0$ to 2K			880 810 420	mW mW mW
P_{dq}	Active, $R_{feed} = 400\Omega$ $I_{LIM} = 25mA$ $I_{LIM} = 44mA$ $I_{LIM} = 55mA$	$R_L = 0$ to 2K $R_L = 0$ to 2K $R_L = 0$ to 2K			1080 1610 1670	mW mW mW

SUPPLY CURRENTS

ANALOG SUPPLY						
I_{CC}	V_{CC}	Power Down		1.5	2.2	mA
I_{SS}	V_{SS}	Power Down		0.1	0.5	mA
I_{CC}	V_{CC}	Stand-by / A open		4	5	mA
I_{SS}	V_{SS}	Stand-by / A open		1.5	3	mA
I_{CC}	V_{CC}	Active		6	10	mA
I_{SS}	V_{SS}	Active		3	6	mA
BATTERY SUPPLY						
I_{bat}	Power down	a or b to BGND		120	500	μA
I_{bat}	Stand-by	2-wire open		1.4	2	mA
I_{bat}	Active	2-wire open 2-wire $R_L = 400\Omega$		2.3	3 I_{LOOP+5}	mA mA

ELECTRICAL CHARACTERISTICS (continued)

Symbol	Parameter	Test Condition	Min.	Typ.	Max.	Unit
--------	-----------	----------------	------	------	------	------

POWER SUPPLY REJECTION ($V_{RIPPLE} = 100mV_{rms}$)

LINE TERMINALS						
PSRR	V_{CC} ref to AGND	50Hz to 3.4KHz	20			dB
PSRR	V_{SS} ref to AGND		20			dB
PSRR	V_{bat} ref to AGND		30			dB
PSRR	BGND ref to AGND		20			dB

RELAY DRIVER

i_{RD}	Current Capability		40			mA
V	Voltage Drop	@ $i_{RD} = 40mA$			1.25	V
i_{LK}	Off Leakage Current				100	μA

Figure 6: Test Circuit

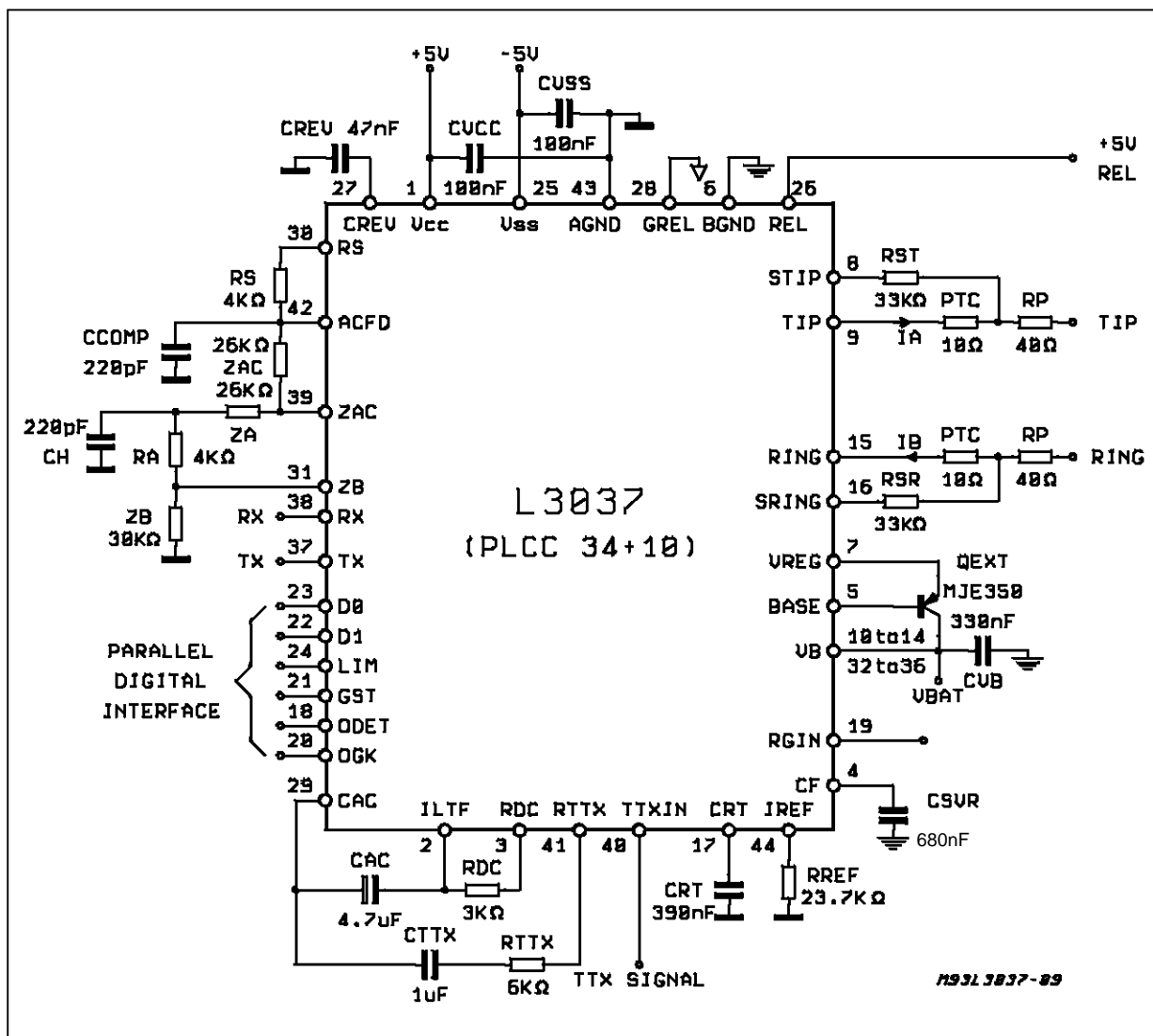

Figure 8: Typical Application with 1st Generation COMBO (600Ω Application)

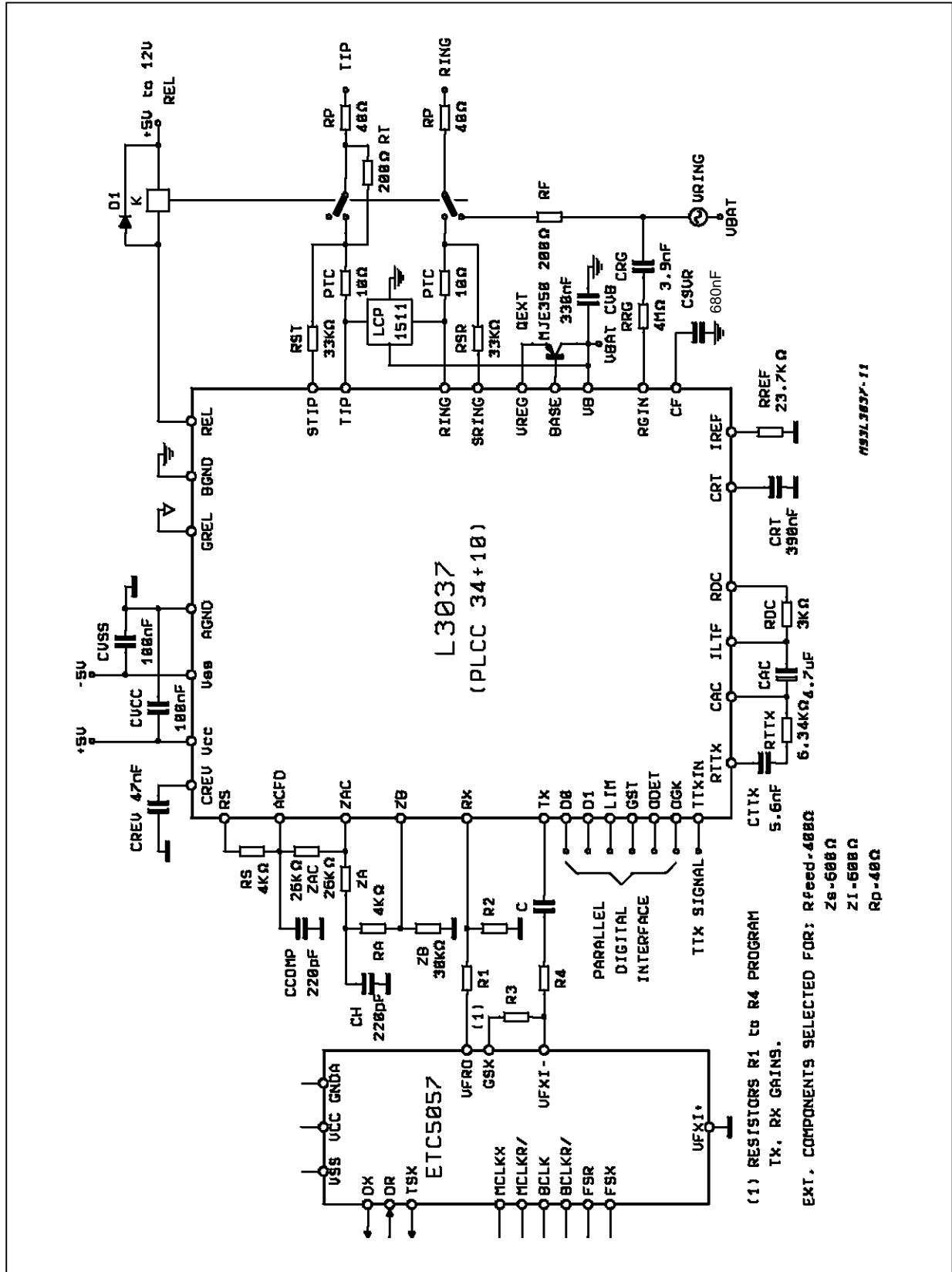
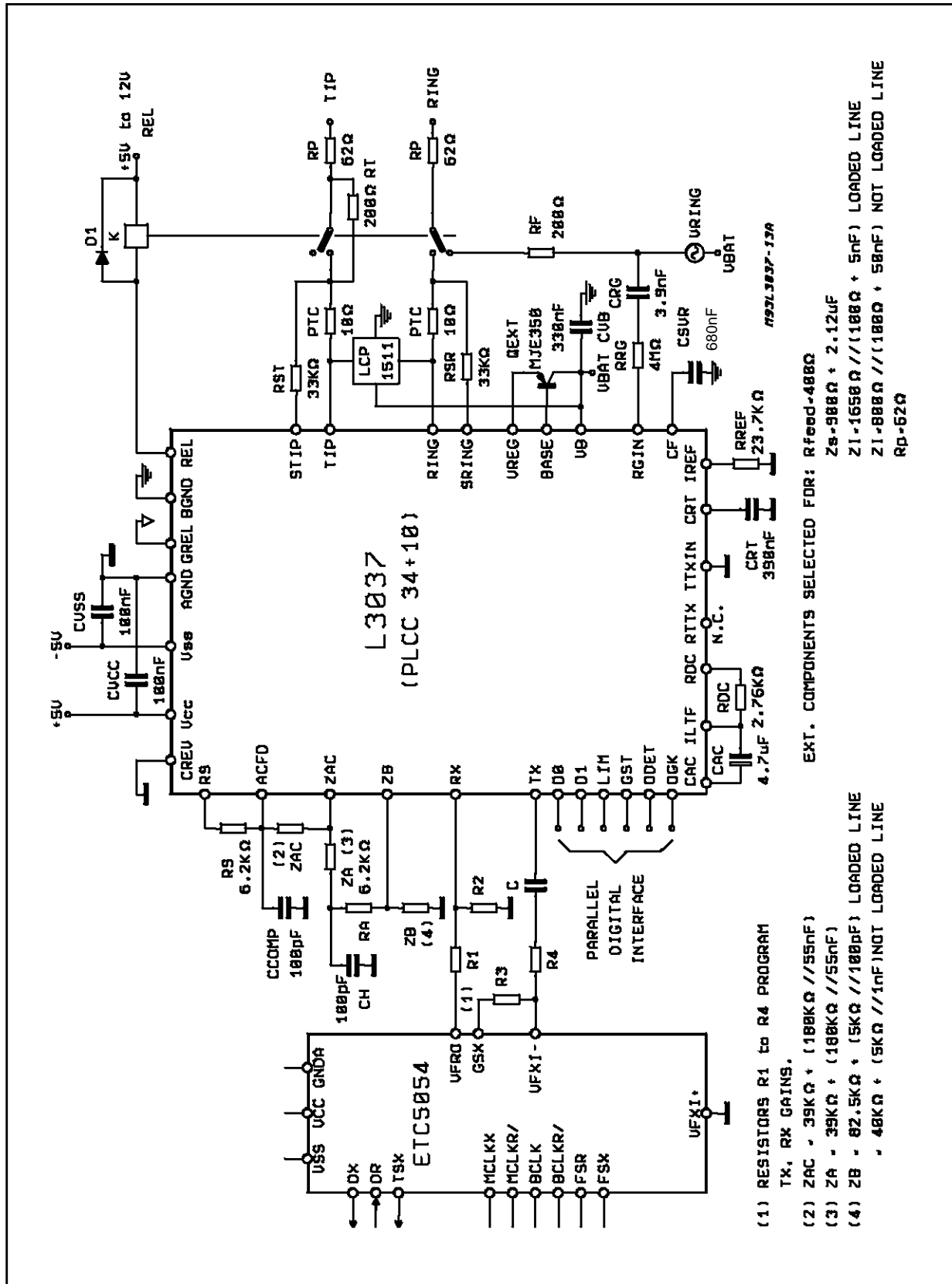
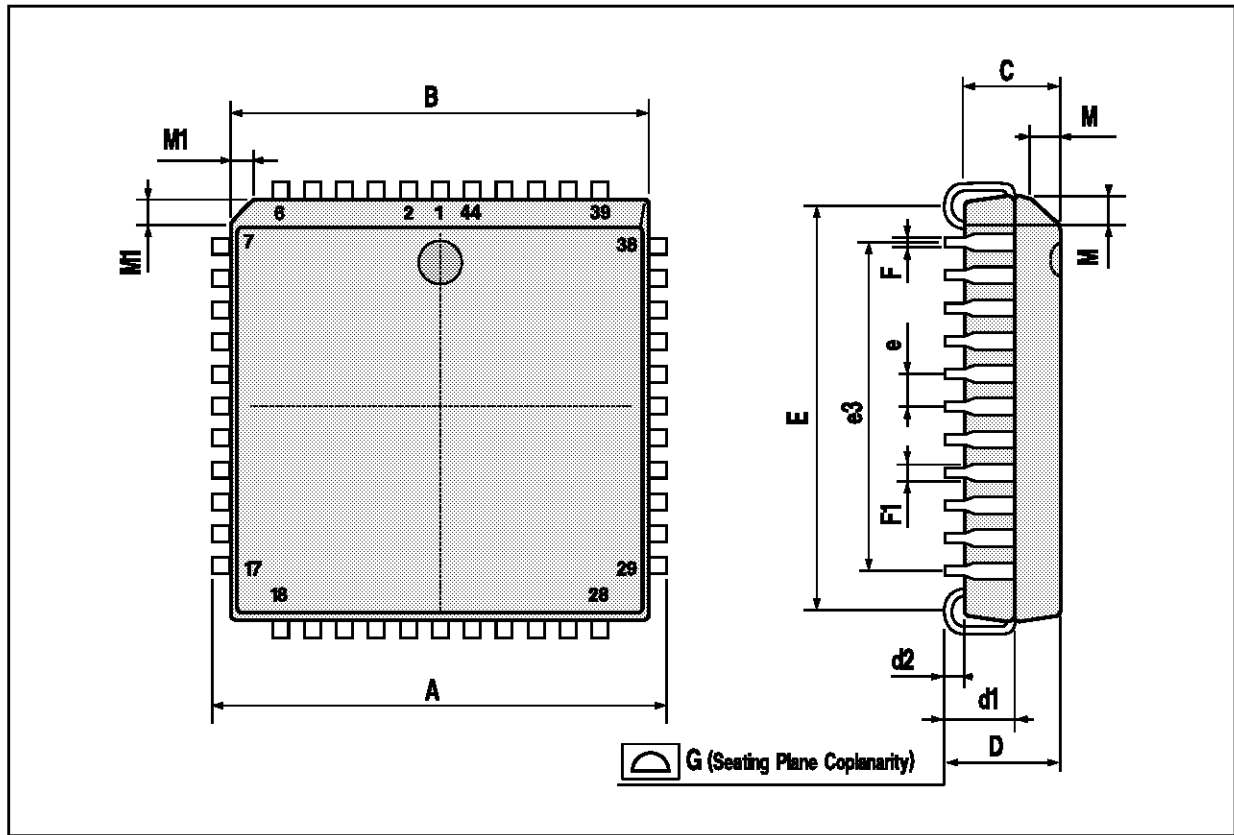

Figure 10: Typical application with 1st Generation COMBO (U.S. Application)



PLCC44 PACKAGE MECHANICAL DATA

DIM.	mm			inch		
	MIN.	TYP.	MAX.	MIN.	TYP.	MAX.
A	17.4		17.65	0.685		0.695
B	16.51		16.65	0.650		0.656
C	3.65		3.7	0.144		0.146
D	4.2		4.57	0.165		0.180
d1	2.59		2.74	0.102		0.108
d2		0.68			0.027	
E	14.99		16	0.590		0.630
e		1.27			0.050	
e3		12.7			0.500	
F		0.46			0.018	
F1		0.71			0.028	
G			0.101			0.004
M		1.16			0.046	
M1		1.14			0.045	



PQFP44(10 x 10) PACKAGE MECHANICAL DATA

DIM.	mm			inch		
	MIN.	TYP.	MAX.	MIN.	TYP.	MAX.
A			2.45			0.096
A1	0.25			0.010		
A2	1.95	2.00	2.10	0.077	0.079	0.083
B	0.30		0.45	0.012		0.018
c	0.13		0.23	0.005		0.009
D	12.95	13.20	13.45	0.51	0.52	0.53
D1	9.90	10.00	10.10	0.390	0.394	0.398
D3		8.00			0.315	
e		0.80			0.031	
E	12.95	13.20	13.45	0.510	0.520	0.530
E1	9.90	10.00	10.10	0.390	0.394	0.398
E3		8.00			0.315	
L	0.65	0.80	0.95	0.026	0.031	0.037
L1		1.60			0.063	
K	0°(min.), 7°(max.)					

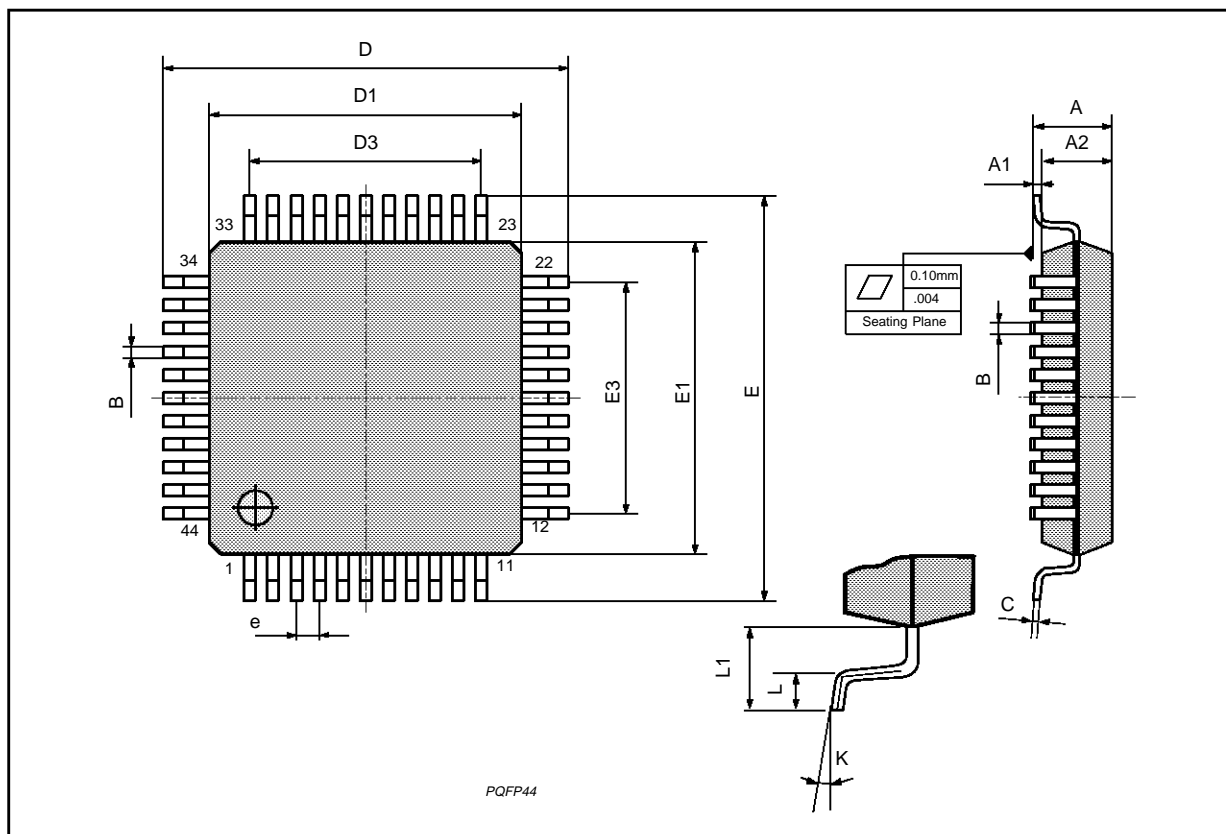

Information furnished is believed to be accurate and reliable. However, SGS-THOMSON Microelectronics assumes no responsibility for the consequences of use of such information nor for any infringement of patents or other rights of third parties which may result from its use. No license is granted by implication or otherwise under any patent or patent rights of SGS-THOMSON Microelectronics. Specifications mentioned in this publication are subject to change without notice. This publication supersedes and replaces all information previously supplied. SGS-THOMSON Microelectronics products are not authorized for use as critical components in life support devices or systems without express written approval of SGS-THOMSON Microelectronics.

© 1995 SGS-THOMSON Microelectronics - All Rights Reserved

SGS-THOMSON Microelectronics GROUP OF COMPANIES
Australia - Brazil - France - Germany - Hong Kong - Italy - Japan - Korea - Malaysia - Malta - Morocco - The Netherlands
Singapore - Spain - Sweden - Switzerland - Taiwan - Thailand - United Kingdom - U.S.A.